

LV2B Series / 1000 WOG Stainless Steel



- 1000 PSI rating on all sizes
- All stainless steel construction
- Locking handles standard
- Ideal for suction, pressure and return lines
- Available in NPT & SAE threads
- Mounting holes standard on SAE #16 - #32
- Mounting holes optional on all other valves up to 2"

FLOW, NEEDLE & CHECK VALVES

HYDRAULIC BALL VALVES

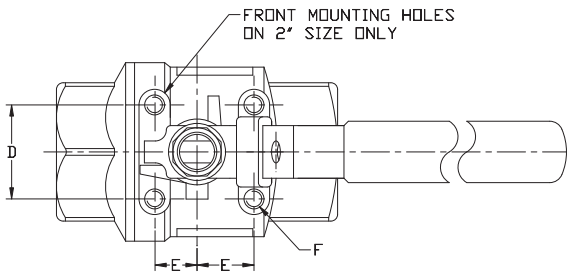

SHOWN WITH OPTIONAL MOUNTING HOLES

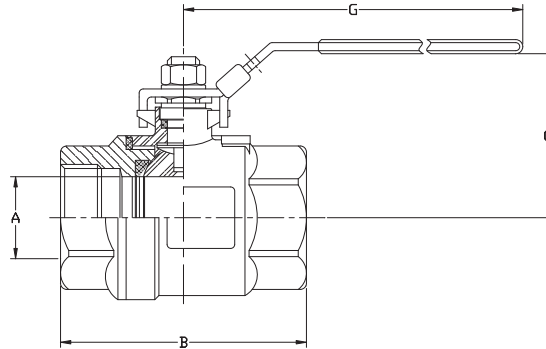

Model Code:

LV2B N 1/2" -2T -MH

Thread type (N-NPT; S-SAE)
Thread size (Ex. N1/2"; #8)

Optional Mounting Holes

WELD COUPLINGS

FLANGES

LV2B SERIES - NPT							
SIZE	A	B	C	D	E	F UNC	G
1/4"	.36	2.13	2.13	1.12	.49	10-24	4.33
3/8"	.50	2.13	2.17	1.12	.49	10-24	4.33
1/2"	.59	2.24	2.28	1.12	.49	10-24	4.53
3/4"	.79	2.68	2.40	1.12	.49	10-24	4.53
1"	.98	3.15	3.03	1.38	.91	1/4-20	5.04
1-1/4"	1.26	3.58	3.19	1.48	1.00	1/4-20	5.04
1-1/2"	1.50	4.06	3.54	1.48	1.00	1/4-20	6.10
2"	1.97	4.88	4.25	1.50	1.00	1/4-20	6.10
2-1/2"	2.56	6.30	5.20	N/A	N/A	N/A	9.06
3"	3.15	7.28	5.71	N/A	N/A	N/A	9.06

LV2B SERIES - SAE							
SIZE	A	B	C	D	E	F UNC	G
1/4"	.35	2.40	2.13	1.12	.49	10-24	4.33
3/8"	.47	2.40	2.17	1.12	.49	10-24	4.33
1/2"	.59	2.52	2.28	1.12	.49	10-24	4.53
3/4"	.79	3.23	2.40	1.12	.49	10-24	4.53
1"	.98	3.62	3.03	1.38	.91	1/4-20	5.04
1-1/4"	1.26	3.96	3.19	1.48	1.00	1/4-20	5.04
1-1/2"	1.50	4.23	3.54	1.48	1.00	1/4-20	6.10
2"	1.97	4.90	4.25	1.50	1.00	1/4-20	6.10

COMPONENT MATERIALS		
COMPONENT	MATERIAL	QTY
VALVE BODY	ASTM A351 GR CF8M	1
TAILPIECE	ASTM A351 GR CF8M	1
BALL	ASTM A351 GR CF8M	1
STEM	316	1
BALL SEAT	PTFE	2
STEM SEAT	PTFE	1
STEM PACKING	PTFE	1
STEM GLAND	304	1
HANDLE	304	1
STEM LOCK WASHER	304	1
STEM NUT	304	1
HANDLE SLEEVE	VINYL	1
LOCK	304	1