

ABS Series / Two-Way Round Body Flange Head

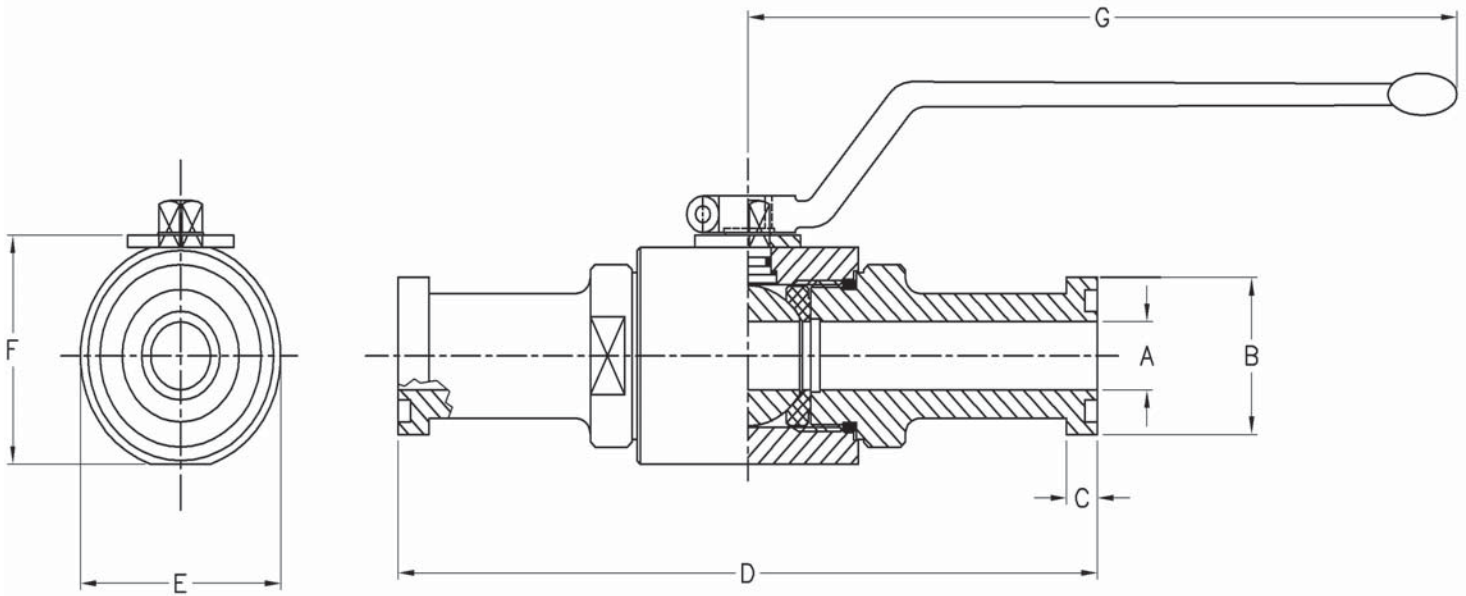

- Carbon steel construction with Silver Trivalent plating
- 316 stainless steel available from stock
- POM seats & Buna O-rings standard on carbon steel valves
- Optional seal materials available for extreme temperature applications & fluid compatibility (*Consult Factory*)



Standard handle supplied is C92501Z-SW17. Refer to page 47 for details.

ABS SERIES - CODE 61									
SERIES	PSI MAX	A BORE	B	C	D	E	F	G	WEIGHT
ABS3#20	4000	1.18	2.00	.32	7.52	3.88	3.66	12.31	9.2 LBS
ABS3#24	3000	1.42	2.37	.32	9.10	4.45	4.21	12.31	15.1 LBS
ABS3#32	3000	1.89	2.81	.38	9.13	4.84	4.49	12.31	16.5 LBS

ABS SERIES - CODE 62									
SERIES	PSI MAX	A BORE	B	C	D	E	F	G	WEIGHT
ABS6#20	5000	1.06	2.13	.41	8.78	3.88	3.66	12.31	10.1 LBS
ABS6#24	5000	1.26	2.50	.50	11.06	4.45	4.21	12.31	15.1 LBS
ABS6#32	5000	1.77	3.13	.50	12.44	4.84	4.49	12.31	20.6 LBS

FLOW, NEEDLE & CHECK VALVES

HYDRAULIC BALL VALVES

WELD COUPLINGS

FLANGES



ABS Series / Two-Way Round Body Flange Head

Model Code Breakdown

ABS3 #32 - 1 1 D B _

Valve Series •

ABS3	Code 61
ABS6	Code 62

Connection Size •

Body & Adapter Material •

1	Carbon Steel
2	316 Stainless Steel

Ball & Stem Material •

1	Carbon Steel
2	316 Stainless Steel

Locking Kit or Optional Handle Code

(See pages 42 & 43)

Adapter & Stem Seals

B	Buna- Standard
V	Viton (Std on S/S)

Ball & Stem Seats

D	POM- Standard
P	PEEK
N	PA612
X	PTFE w/metallic insert

- Please consult your system's seal manufacturer for recommendation of seal selection, as Anchor Fluid Power does not accept responsibility for seal selection.

MAXIMUM & MINIMUM WORKING TEMPERATURES FOR SEAL MATERIALS

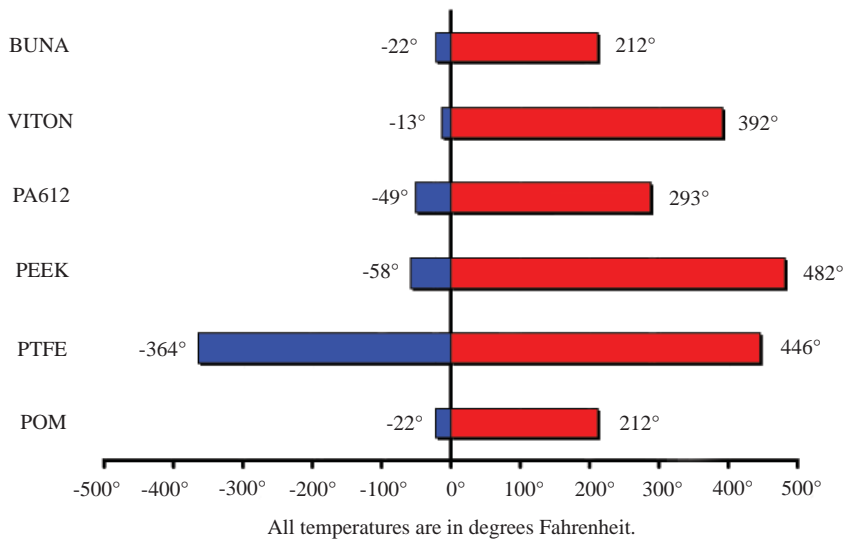

FLOW, NEEDLE & CHECK VALVES

HYDRAULIC BALL VALVES

WELD COUPLINGS

FLANGES