

Flow Control Valves (Carbon Steel)

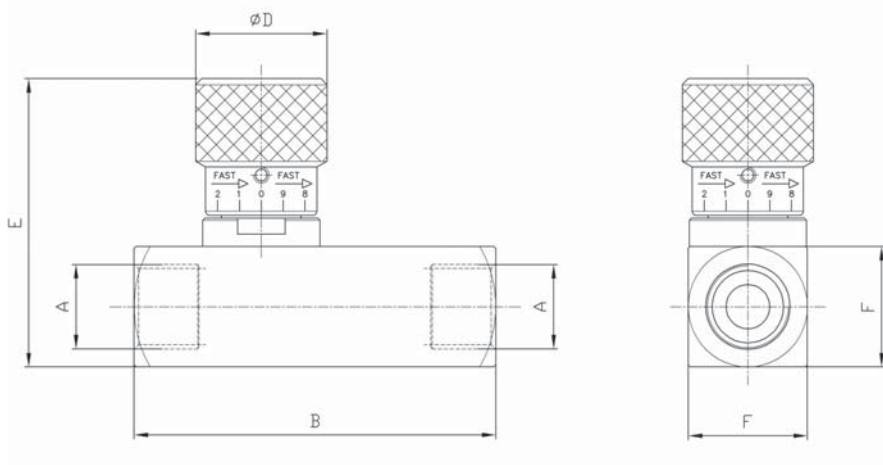

- NPTF & SAE Connections
- Carbon Steel With Zinc Dichromate Plating
- Set Screw Allows Knob to be Locked into Position
- Graduated Knob & Spindle for Accurate Flow Control
- 7 PSI Standard Spring Setting
- Buna O-Ring / PTFE Stem Packing
- Temperature Range -4°F to +176°F

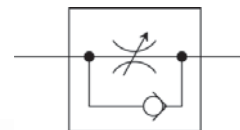

FLOW CONTROL VALVES						
A		B	D	E	F	MAX PSI
NPTF	SAE					
1/4	#4	2.60	1.18	2.67	0.98	5700
3/8	#6	3.00	1.18	2.67	0.98	5700
1/2	#8	3.58	1.29	2.79	1.18	5700
3/4	#12	4.43	1.65	3.70	1.57	5700
1	#16	5.55	1.65	3.93	1.77	5700

FLOW, NEEDLE & CHECK VALVES

HYDRAULIC BALL VALVES

WELD COUPLINGS

FLANGES

Model Code Breakdown

F N 1/2 - 1

Valve Series •

Thread Type •

N	NPTF Pipe Thread
S#	SAE Straight Thread
B#	BSPF Thread

Material

1	Carbon Steel
---	--------------

Thread Size

Example	N1/2
	S#8

Free Flow

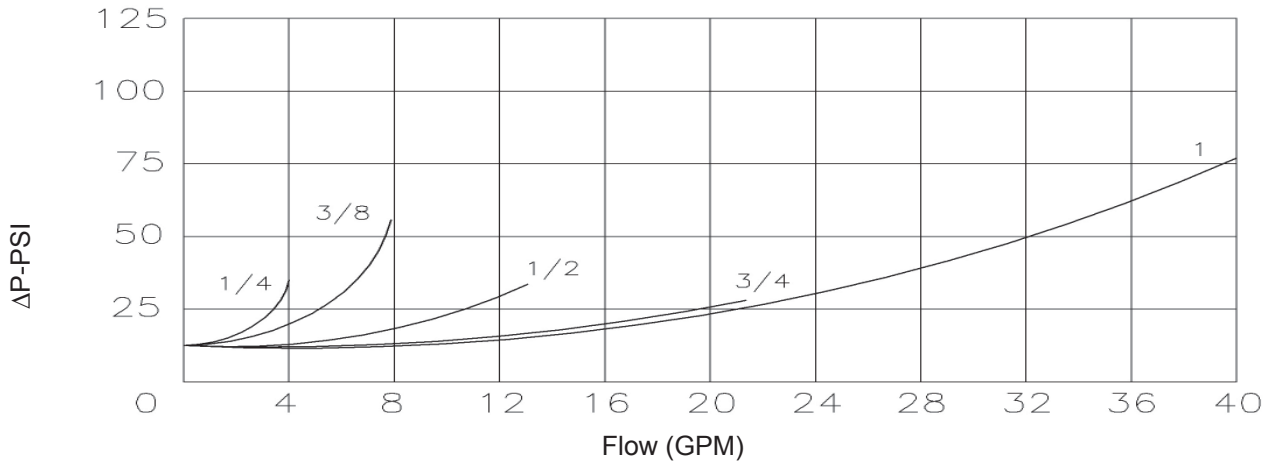

Metered Fully Open

